

- ŁOŻYSKA - PROJEKTY OEM MRO
- JACHTY, ŁODZIE MOTOROWE
- PLATFORMY WIERTNICZE

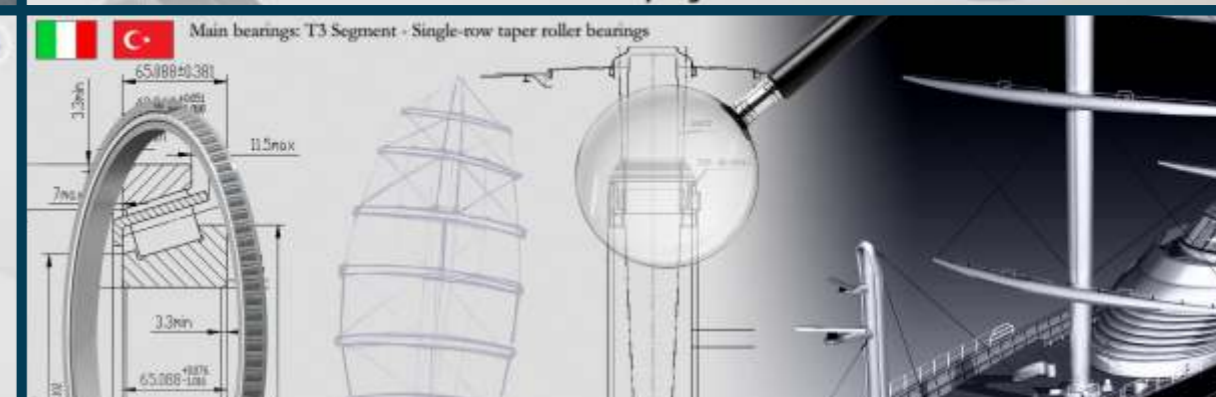

ŁOŻYSKA TECHNOLOGICZNE DLA PRZEMYSŁU MORSKIEGO

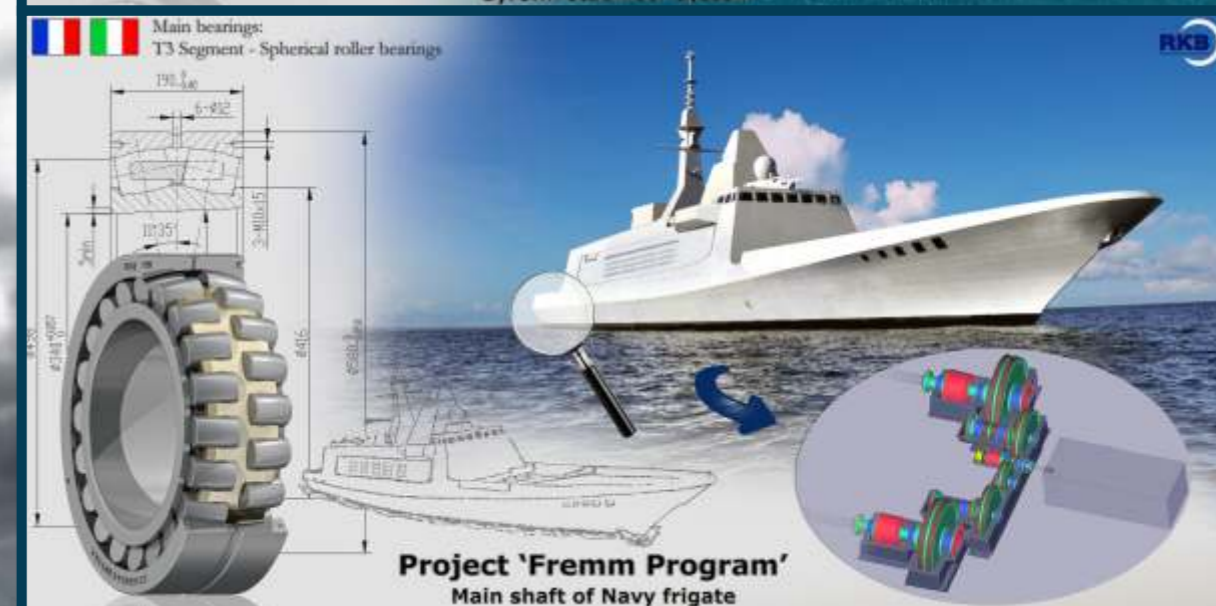

Main bearings:  
T3 Segment - Spherical roller bearings

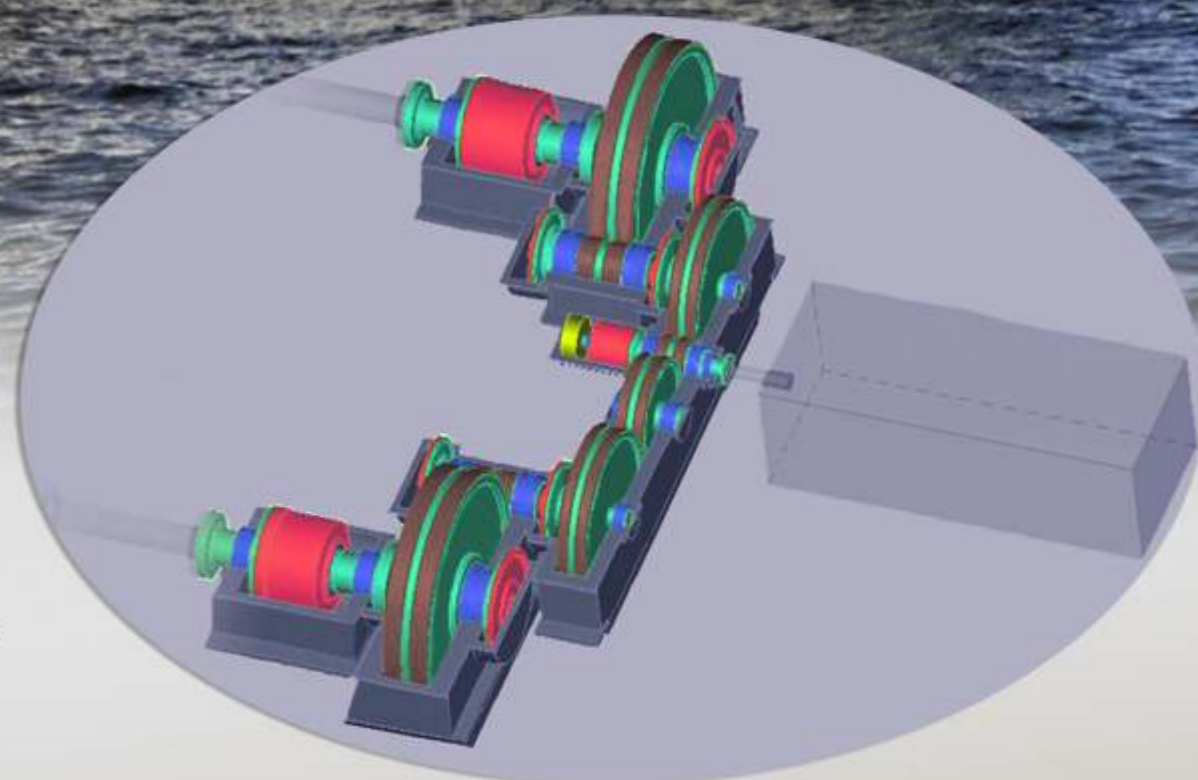
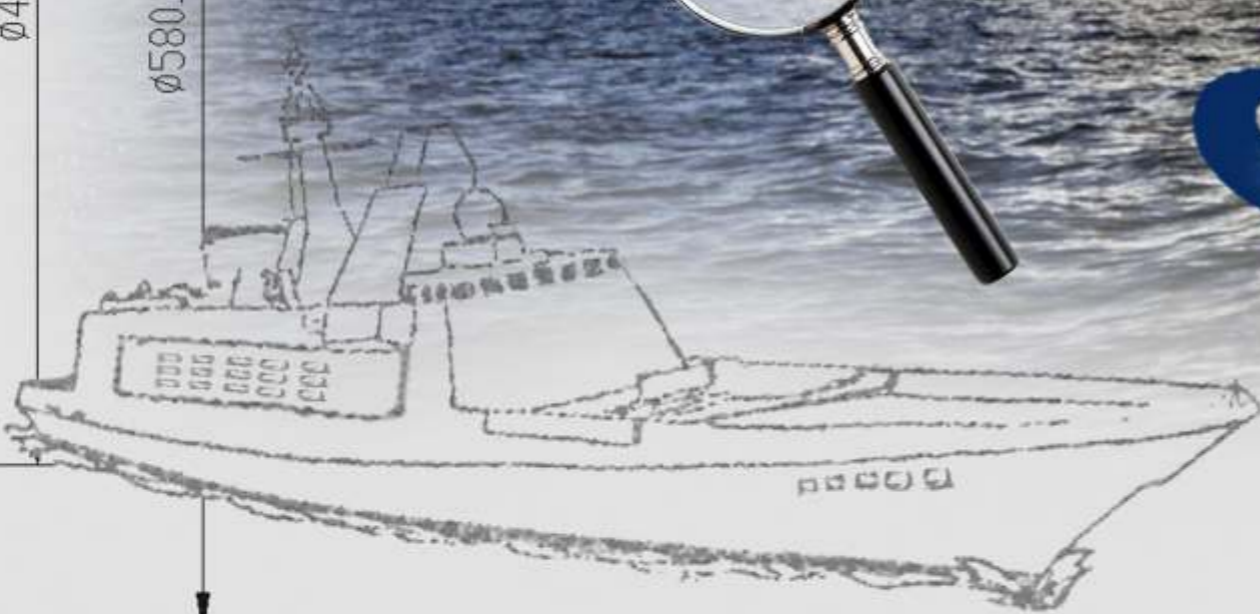
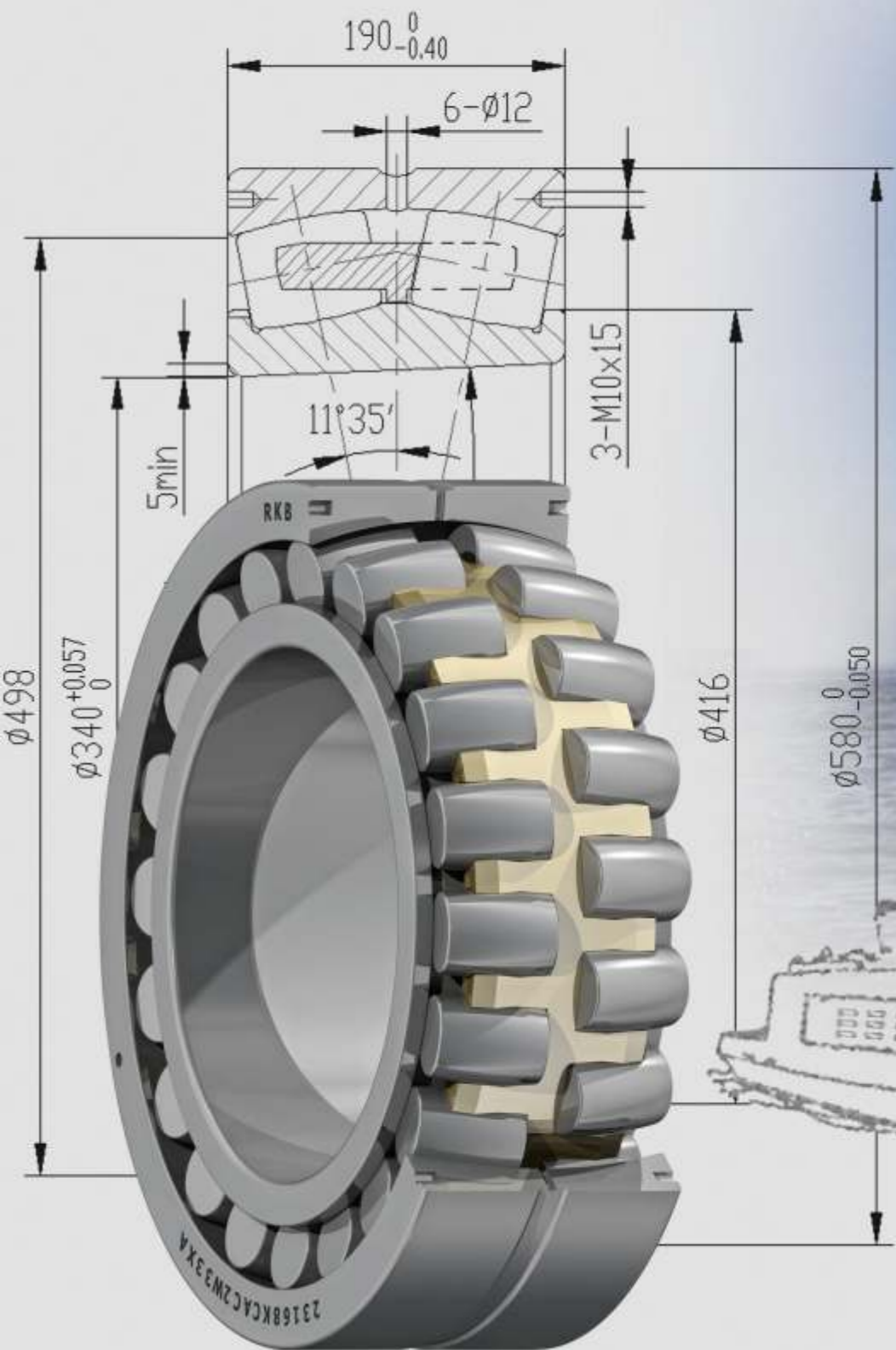

**Project 'Fremm Program'**  
Main shaft of Navy frigate



Main bearings:  
T3 Segment - Spherical roller bearings



Big size application optimized spherical roller bearings

Up to 340 mm inner diameter

Safety factor ( $S_0$ ) according to military offshore equipment guidelines

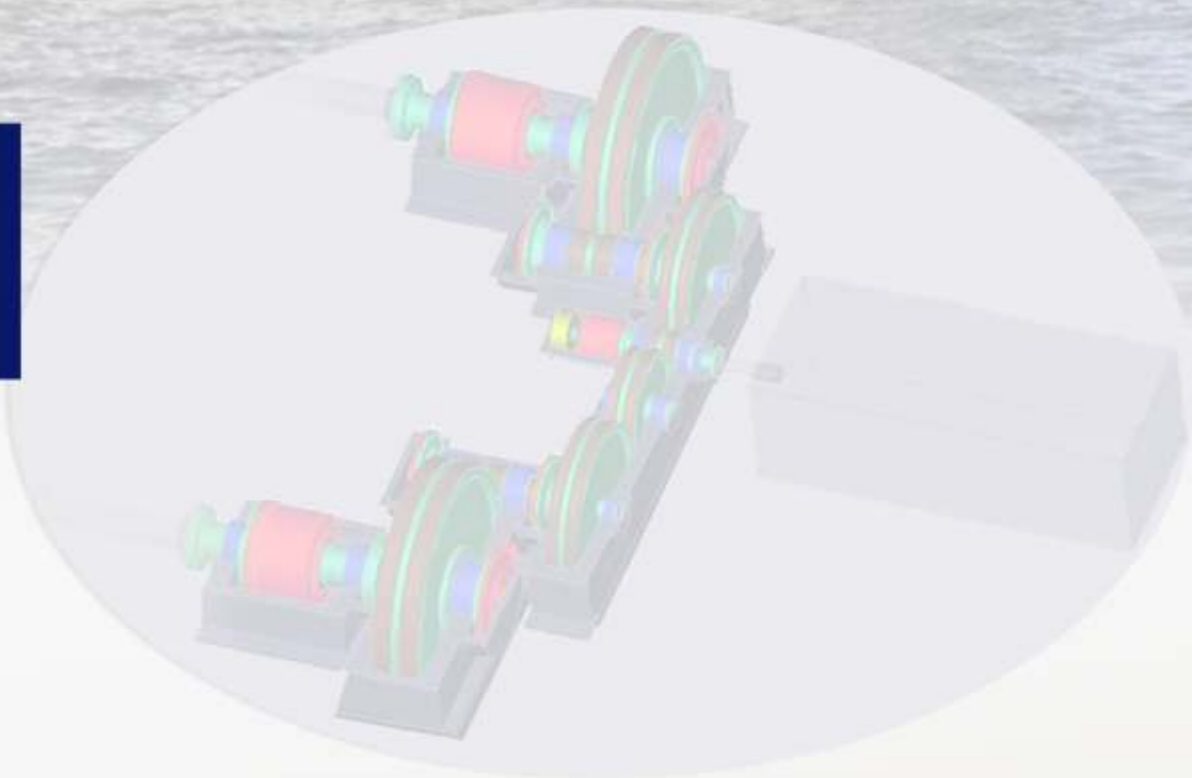

**Project 'Fremm Program'**  
Main shaft of Navy frigate



Main bearings:  
T3 Segment - Double-row taper roller bearings



**Project 'Stabilizer Fin'**  
Gyrofin stabilizer system

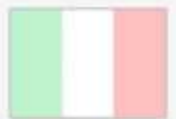

Main bearings:

T3 Segment - Double-row taper roller bearings

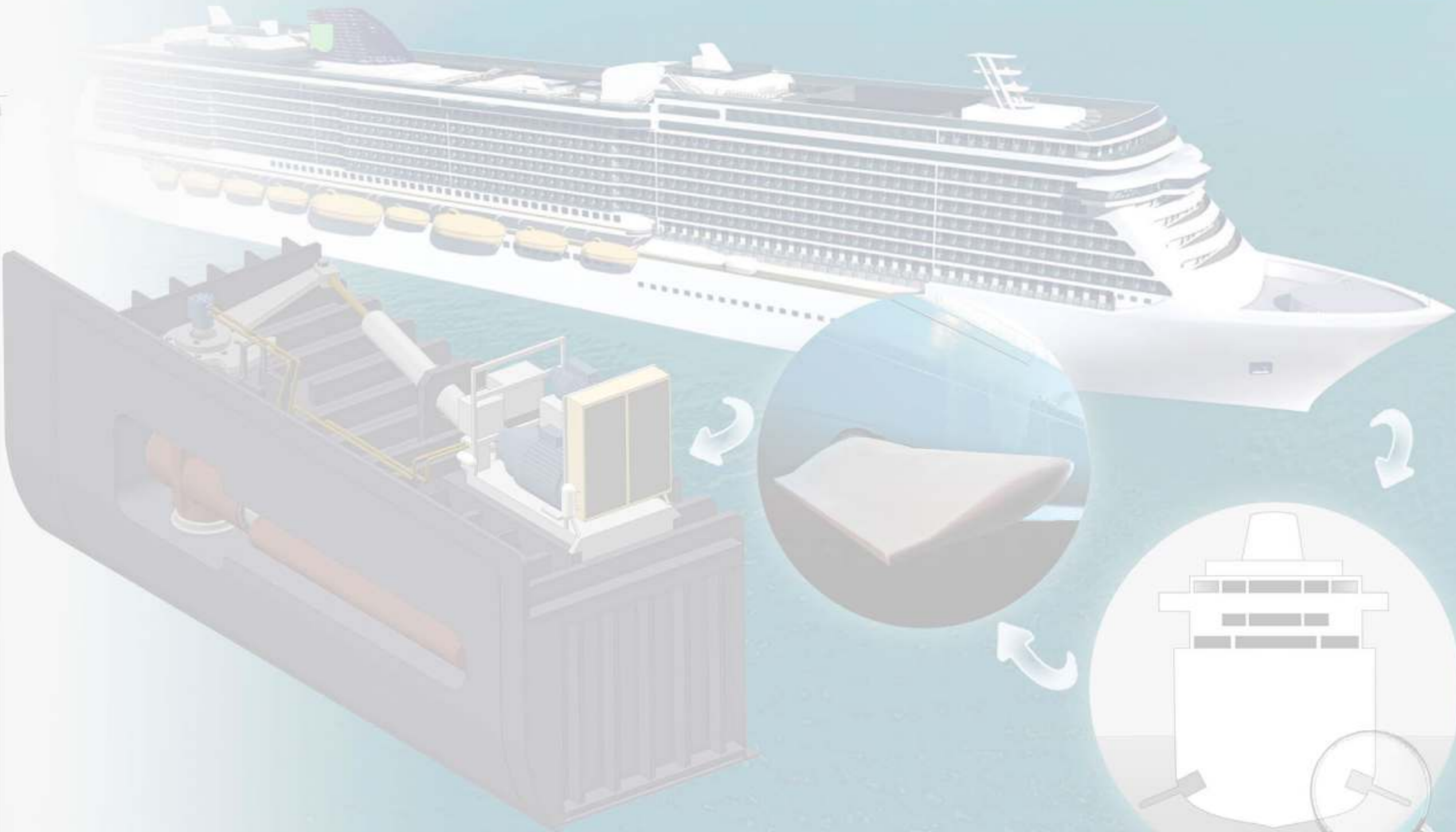

**Project 'Stabilizer Fin'**  
Gyrofin stabilizer system



Main bearings: T3 Segment - Single-row taper roller bearings

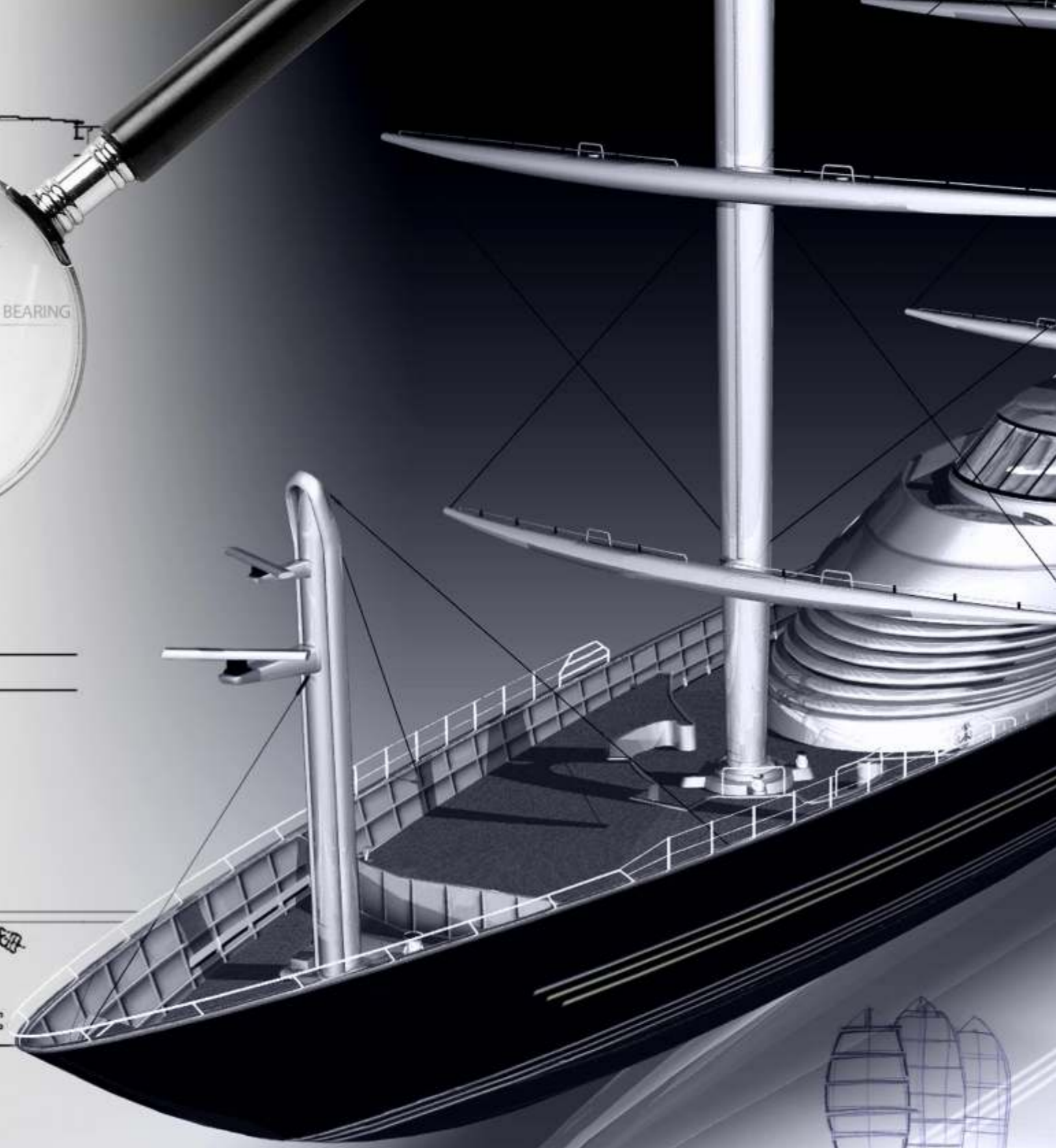
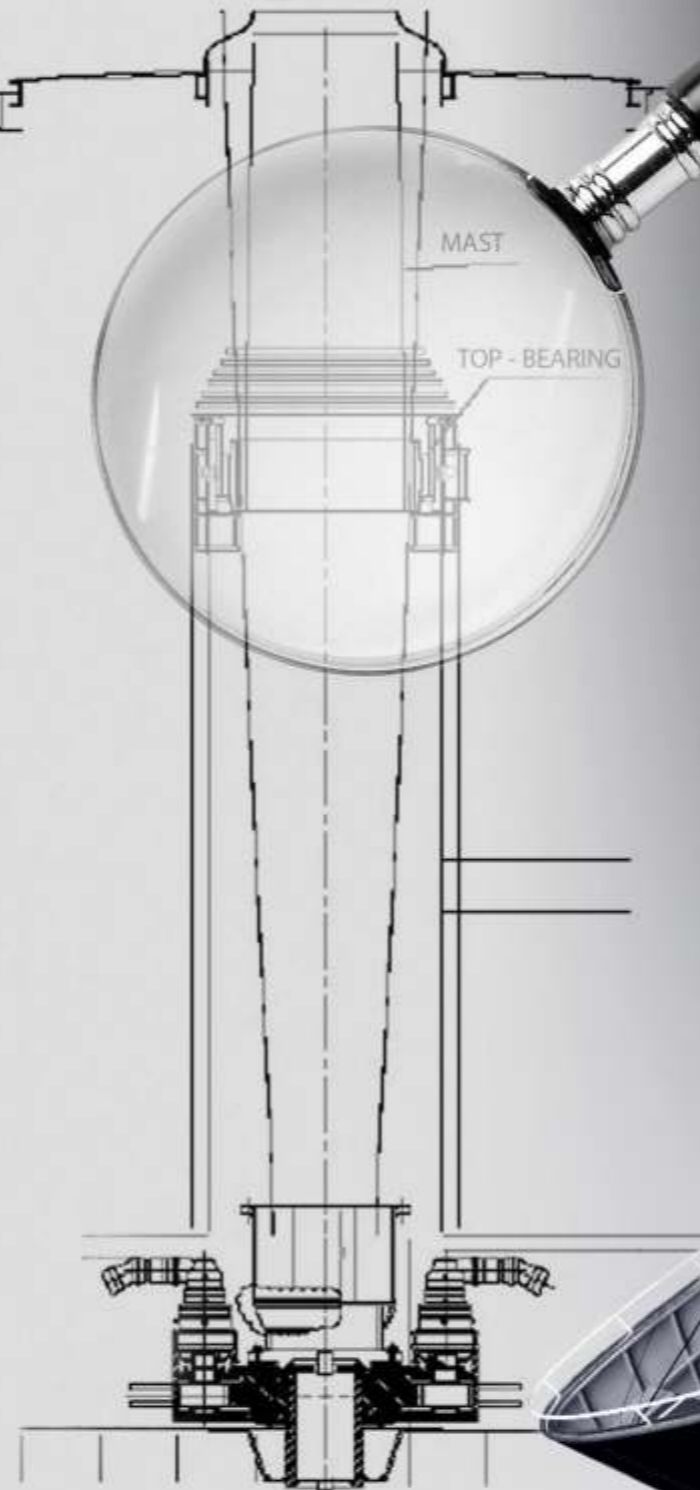
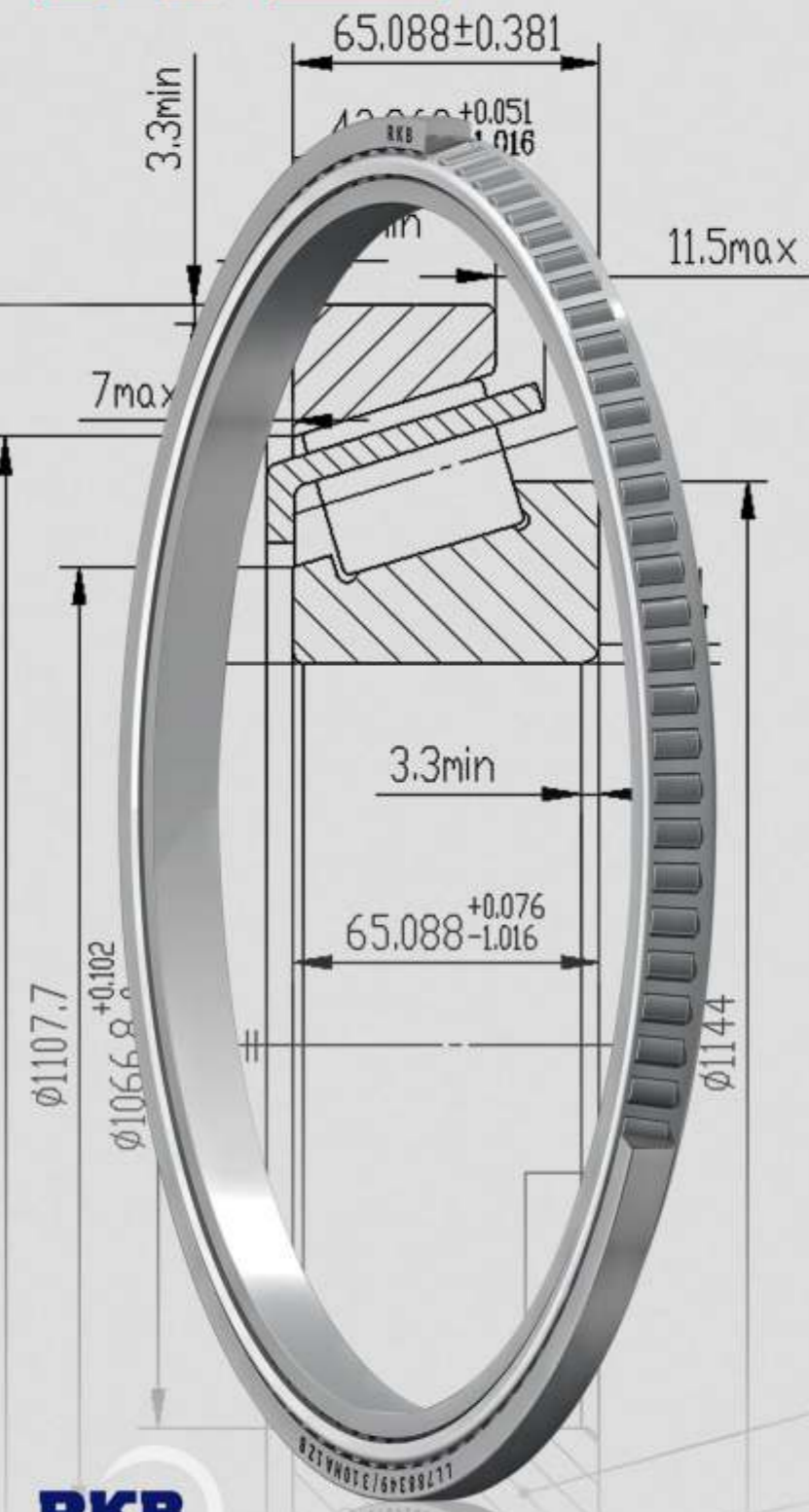

LL788349HA1ZB

RL788000ZB

LL788000ZB

**Project 'Clipper'**

**Masts and spars of sailing yachts**

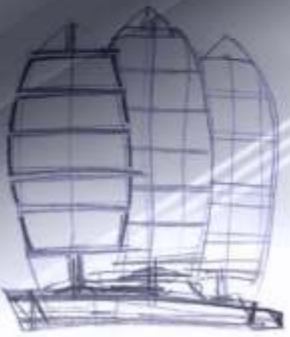

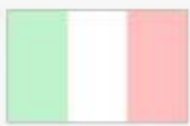

Main bearings: T3 Segment - Single-row taper roller bearings

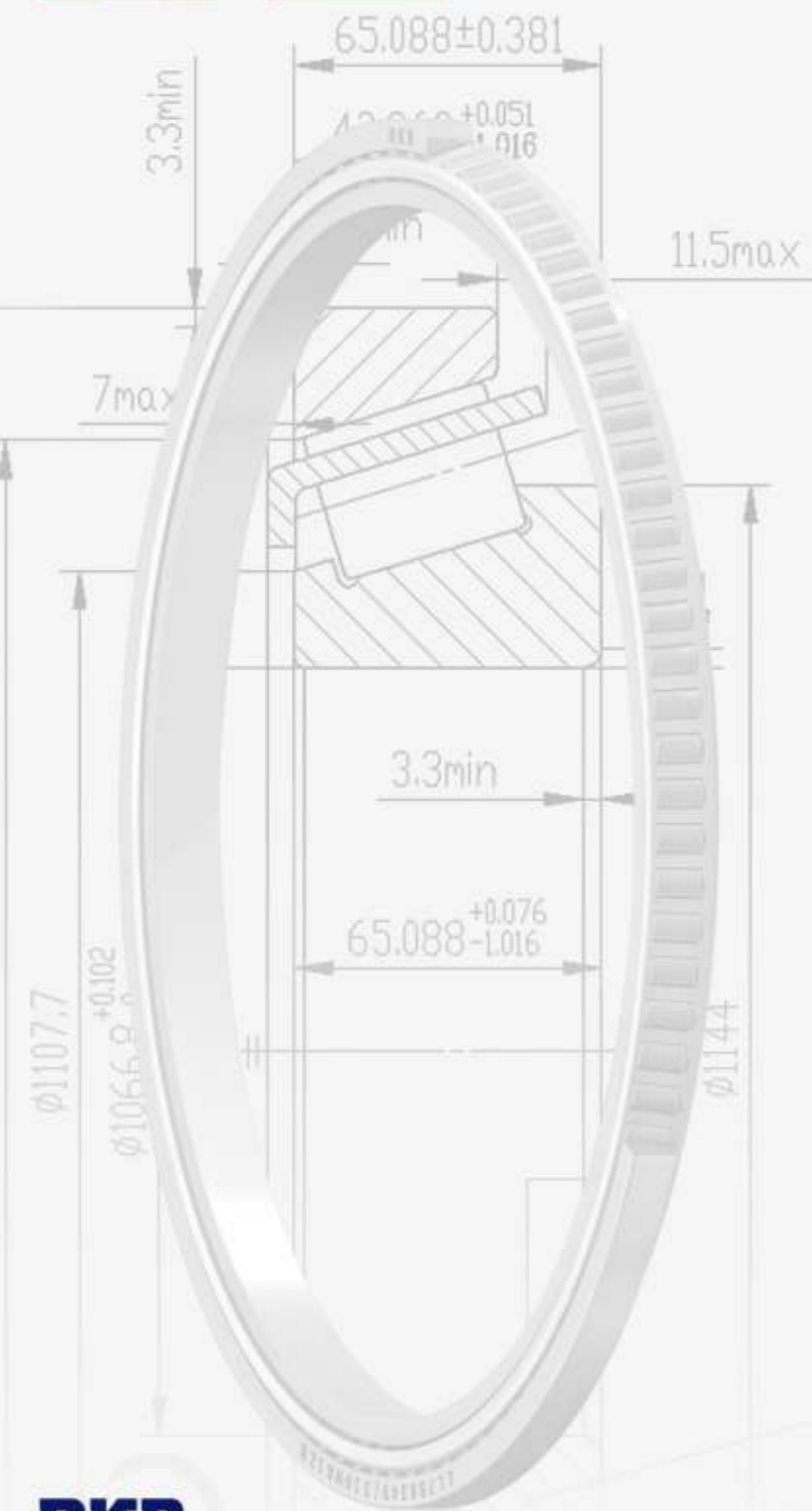

Thin section big size single-row taper roller bearings (design and execution for heavy load applications)

Up to 1067 mm inner diameter

High rigidity of masts and spars with smooth rotation

**Project 'Clipper'**  
Masts and spars of sailing yachts





Main bearings: T3 Segment - Cylindrical roller bearings

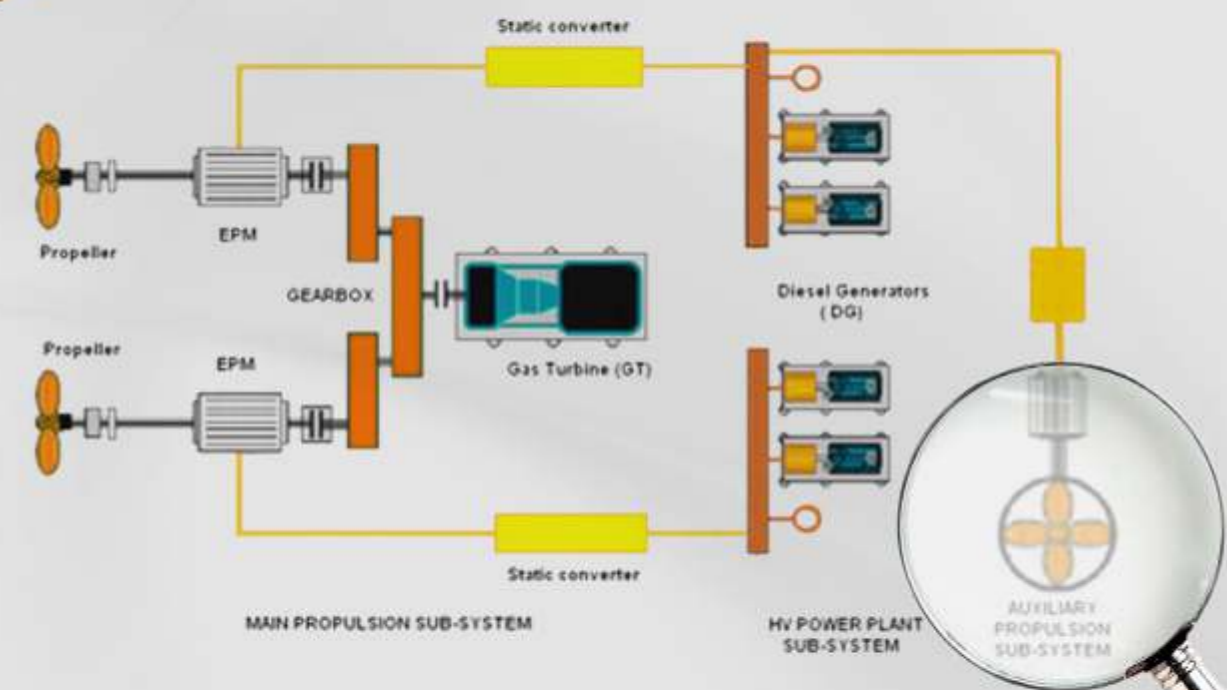
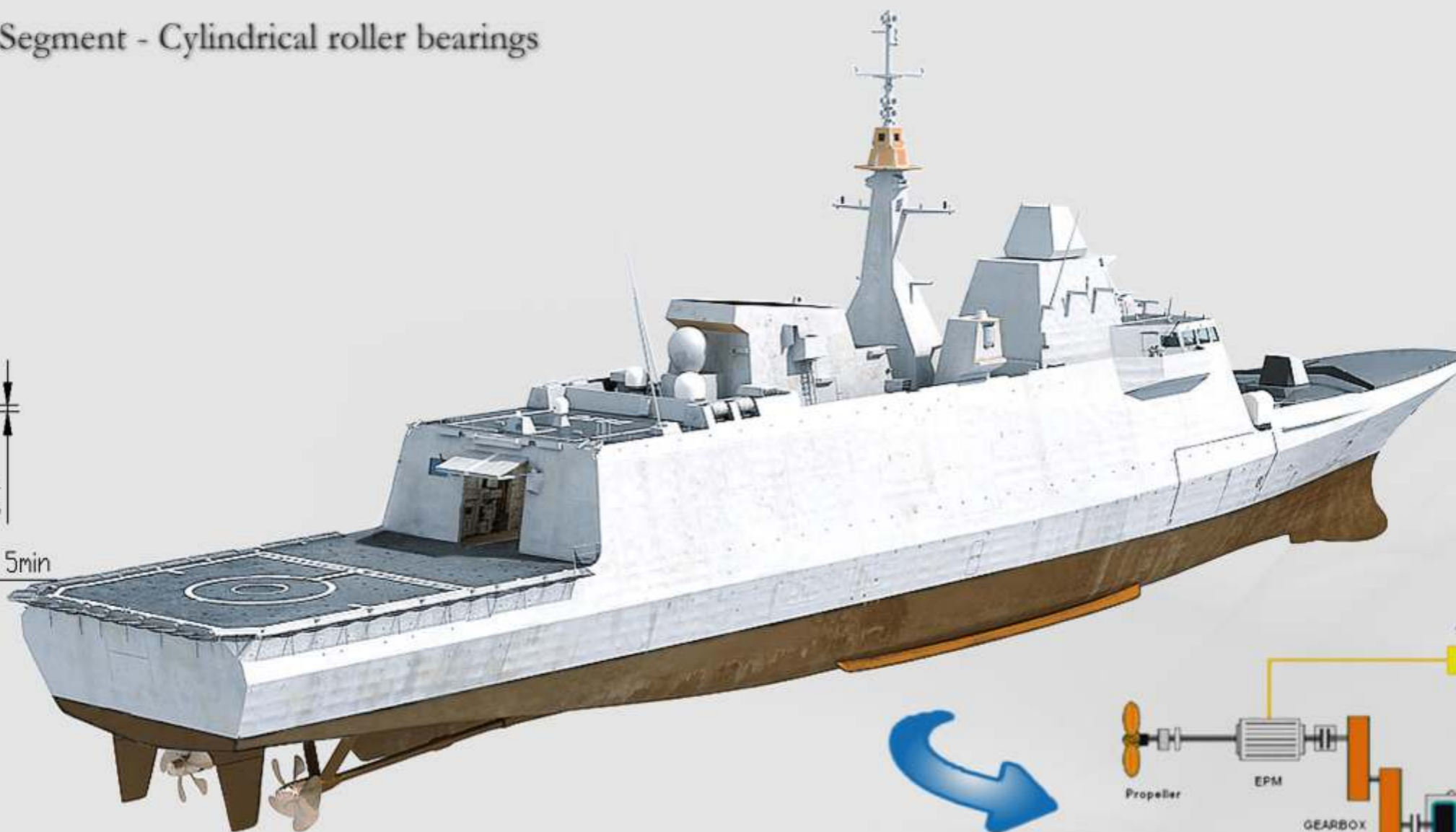
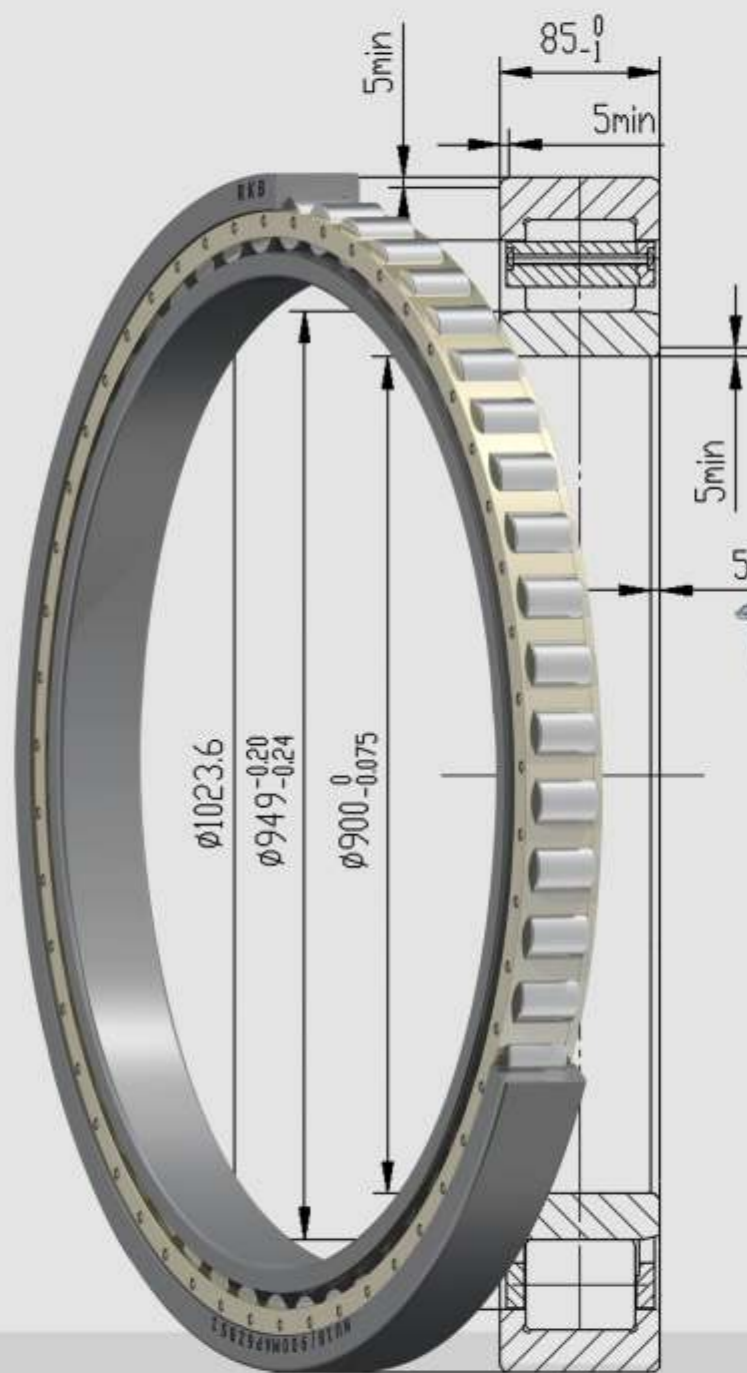

# Project 'Fremm Program II'

## Azimuthal retractable thruster





Main bearings: T3 Segment - Cylindrical roller bearings

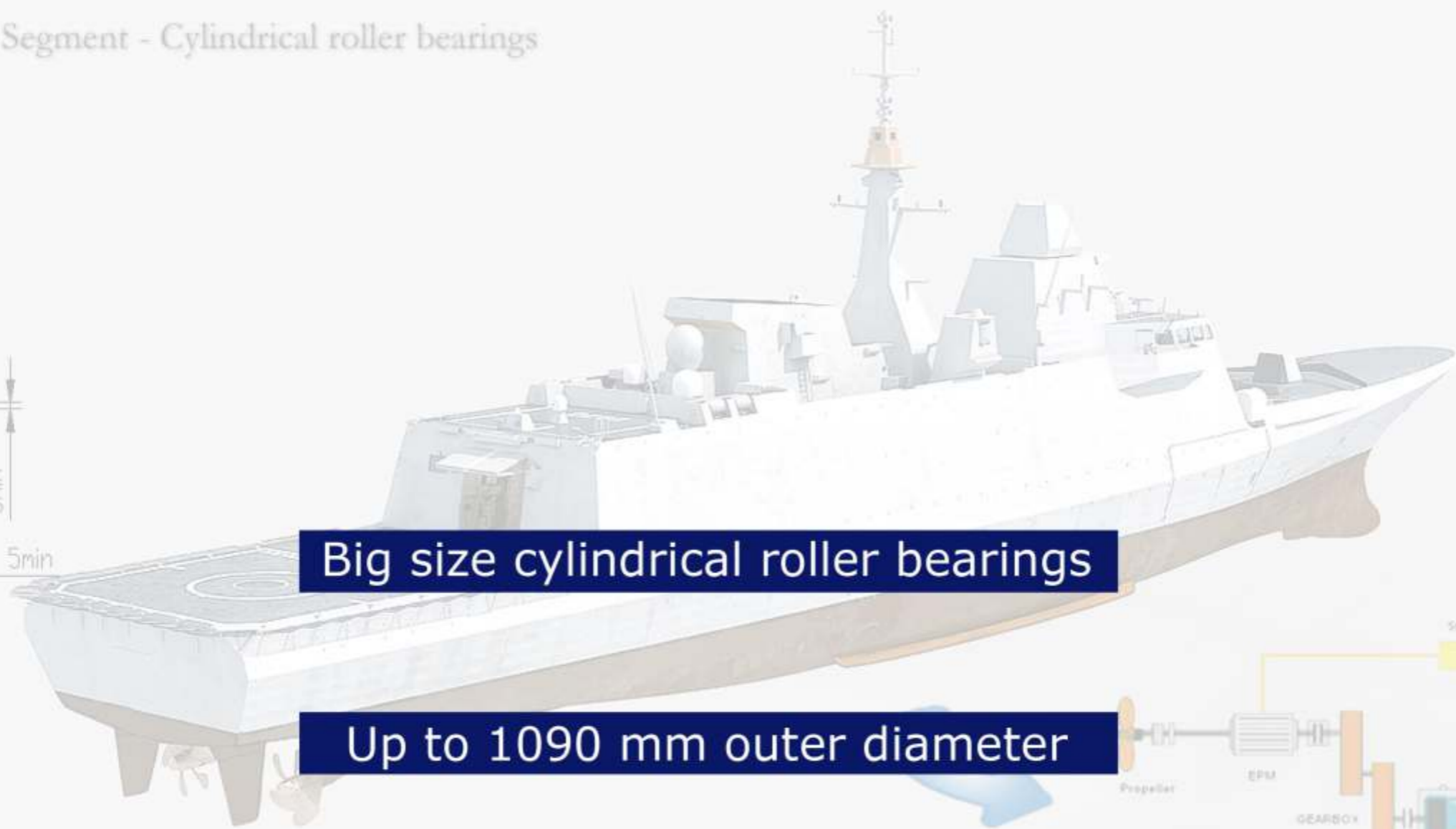
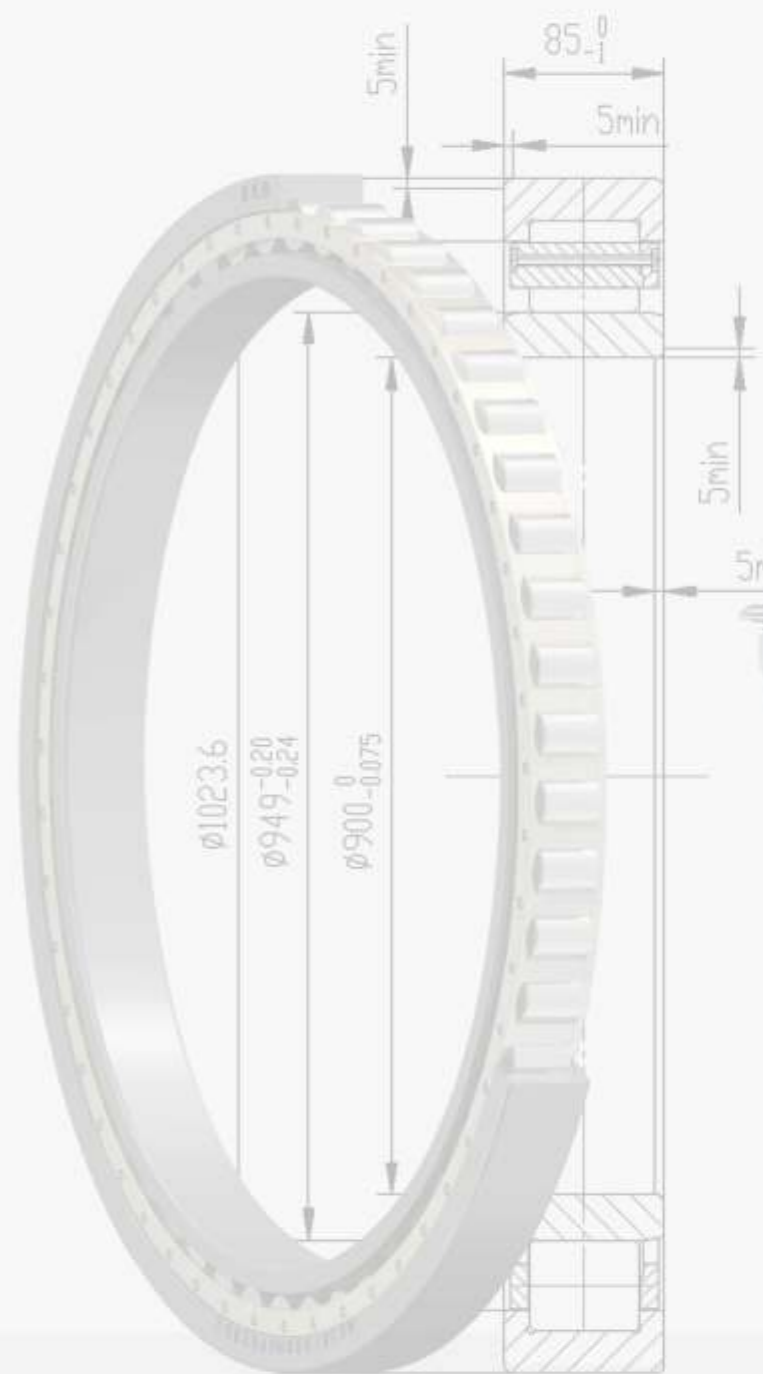

Big size cylindrical roller bearings

Up to 1090 mm outer diameter

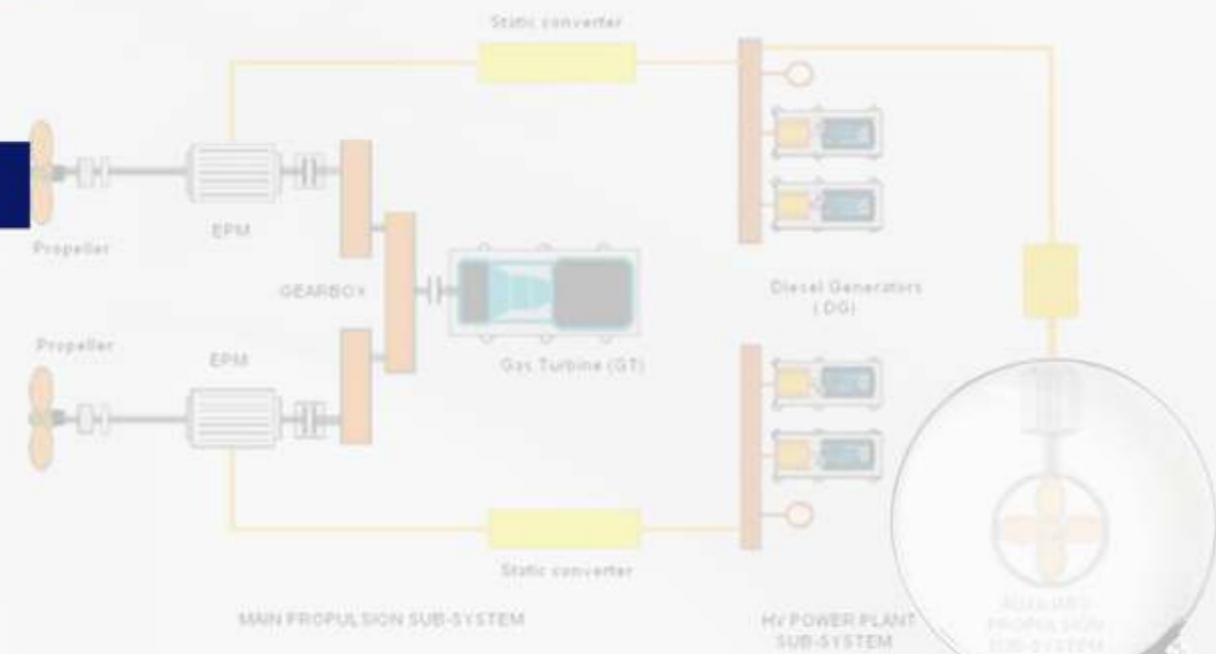

# Project 'Fremm Program II'

## Azimuthal retractable thruster



Main bearings: T3 Segment - Spherical roller bearings

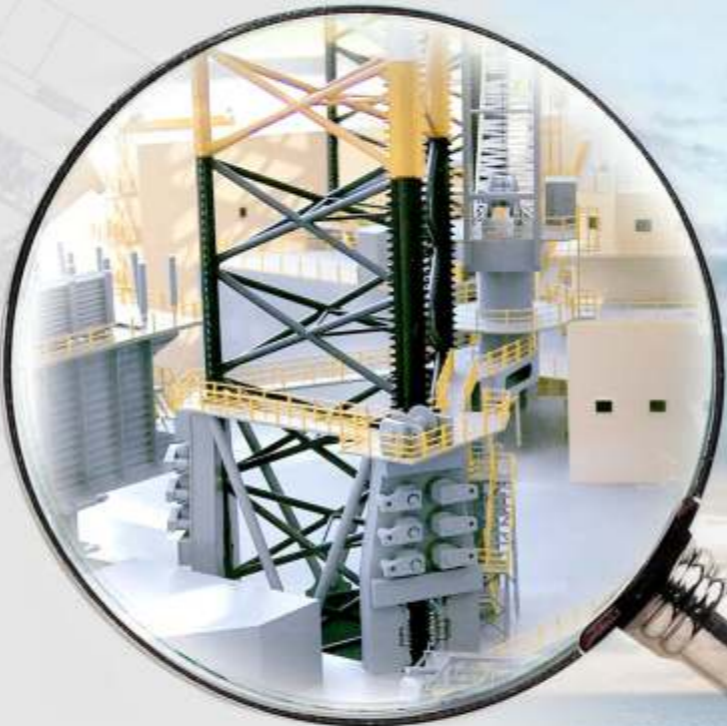

**Project 'MSC'**  
Rack and pinion jacking system  
in offshore platform



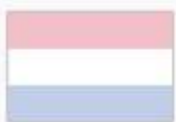

## Main bearings: T3 Segment - Spherical roller bearings

Spherical roller bearings for rack and pinion system of NG and CJ series drilling rigs working in harsh environmental conditions

Up to 240 mm inner diameter

Design and execution to withstand heavy loads and variable speeds (0,3-1,2 m/min)

Safety factor ( $S_0$ ) as per marine specifications

Design life ( $L_{10}$ )  $\approx$  10 years service

Rack and pinion jacking system in offshore platform